

Generating Infrastructural Invisibility: Insulation, Interconnection, and Avian Excrement in the Southern California Power Grid

Etienne Benson

Department of History and Sociology of Science, University of Pennsylvania, USA

ABSTRACT The fact that industrial infrastructures are embedded in complex environments animated by unexpected agencies is often invisible to their users—at least those who live in rich, industrialized societies with reliable systems for distributing water, power, and other goods and services. This article investigates how that invisibility is generated through a case study of electric power transmission in California in the early twentieth century. In the 1910s, the Pacific Light and Power Company constructed a 150,000-volt transmission line that delivered power from the Big Creek hydroelectric complex in the Sierra Nevada to customers in Los Angeles, more than 240 miles (386 kilometers) away. When the Southern California Edison Company upgraded this line to 220,000 volts in the early 1920s, the rate of disruptive “flashovers” on the line jumped dramatically. After months of investigation, the cause was determined to be excrement from birds perching on the transmission towers. To render this and other sources of interruption invisible to users, two techniques were used: insulation and interconnection. These kinds of humble techniques of separation and resilience are ubiquitous in modern infrastructure. By creating and maintaining divisions, they make it possible for new kinds of agency to emerge. Infrastructures become animate: responsive to their environments in ways that allow them to persist in the face of continual change.

Introduction

The drought in California’s Central Valley is in its third year, and the effects are evident even to an occasional visitor such as myself. Next to the dense green groves of irrigated citrus and the sparser nut plantations stretch dusty expanses of desiccated grass. Even the glistening canals that allow the snows of the Sierra Nevada mountains to slake the thirst of one of the world’s most productive (as well as energy-, capital-, and labor-intensive) agricultural regions somehow seem parched between their concrete walls. Humans, too, are hurting for lack of water; the roadside billboards I drive past attempt to convince me and other automobilists that environmentalist restrictions on water flow need to be lifted to keep the Central Valley’s farmers prosperous and Americans well fed: “No Water ... No Food.” The overall impression is

Copyright: © Benson 2015

This is an open access article distributed under the terms of a Creative Commons License (CC BY-NC-ND 3.0). This license permits use and distribution of the article for non-commercial purposes, provided the original work is cited and is not altered or transformed.

of a landscape that has been profoundly transformed to serve human needs but nonetheless remains vulnerable to powerful nonhuman forces.¹

While it is hard to ignore the effects of the drought, my attention is mainly directed not down toward the earth but up toward the sky. I am looking for birds and power lines, and for encounters between the two. In the early 1920s, birds—particularly hawks and other raptors—posed a surprisingly serious threat to the transmission of electrical power from hydroelectric plants in the Sierra Nevada to consumers in Los Angeles. For a few desperate months, it even seemed possible that an expensive and effortful upgrade of the high-voltage lines stretching southward from the Big Creek hydroelectric system east of Fresno to Los Angeles, a distance of more than 240 miles (386 kilometers), might have to be abandoned. The system survived this unexpected threat with the help of two kinds of infrastructural innovation, which I am calling by the names “insulation” and “interconnection.” These are among the strategies that make it possible for infrastructures to seem—and, in certain limited ways, actually to be—independent of the environments that surround them.

Early twentieth-century trade magazines such as *Electrical World* covered the political, economic, and technical aspects of the Big Creek project and other major hydroelectric projects in great detail and with sometimes breathless enthusiasm.² In these magazines, and in several articles written by a Southern California Electric engineer and amateur ornithologist named Harold Michener, I have found evidence that bird-related outages posed a significant and bewildering threat to long-distance, high-voltage power transmission in California during its first few decades. Wary of taking these reports at face value, I have traveled to California in search of further evidence at the Huntington Library in San Marino, just outside of L.A., where the historical records of the Southern California Edison Company are kept. I am also taking advantage of the opportunity to see the dams, generating stations, and power lines with my own eyes, and in the process, I hope, to get some sense of how birds are living with that infrastructure today.

Driving north from L.A., my destination is the collection of dams, reservoirs, tunnels, pipes, and powerhouses that tumbles down the western edge of the Sierra from an altitude of more than 2,300 meters and collectively constitutes the Big Creek Hydroelectric Project (Figure 1). For a few decades after its construction in 1913, Big Creek was the largest single source of electricity for Southern California.³ Although it has long since been overshadowed by other

¹ Amy Quinton, “Drought Could Cost California Agriculture Industry \$1.7 Billion,” KVPR Radio, 19 May, 2014, accessed 2 May 2015, <http://kvpr.org/post/drought-could-cost-california-agriculture-industry-17-billion>. I visited the Central Valley in May 2014; as of spring 2015, the drought continues. California’s fruit growers first began using electrically pumped groundwater to make up for shortfalls in mountain-fed irrigation in the 1920s; Steven Stoll, *The Fruits of Natural Advantage: Making the Industrial Countryside in California* (Berkeley: University of California Press, 1998), 161.

² e.g., “Largest Western Hydro Plant Starts Up,” *Electrical World* 82, no. 16 October (1923): 830.

³ In 1929, the Big Creek system was capable of generating about 360 megawatts, which accounted for more than half of Southern California Edison’s total generating capacity at the time; William A. Myers, *Iron Men and Copper Wires: A Centennial History of the Southern California Edison Company*, 2nd ed., rev. (Glendale, California: Trans-Anglo Books, 1986), 119. For an insider’s account of the expansion of the Big Creek system in the 1920s and 1930s, originally published in 1949, see David H. Redinger,

sources, it is still capable of generating more than 1,000 megawatts—about the capacity of one of the reactors at Diablo Canyon, California’s only remaining nuclear power plant.⁴ In the hope of capturing the interaction of birds and infrastructure on camera, I am following as closely as possible the high-tension transmission lines that connect Big Creek to a substation near Pasadena. There Big Creek’s power—supplemented by electricity generated at other facilities—is reduced to a lower voltage by transformers, directed into numerous smaller distribution lines, and delivered to consumers throughout the Los Angeles area.



Figure 1. Big Creek Power House No. 1, which went into operation in 1913. The penstocks—high-pressure pipes carrying water from upstream reservoirs—can be seen on the mountainside above and just to the right of the power house. Photograph by author.

The Story of Big Creek, with new material by Edith I. Redinger and William A. Myers (Glendale, California: Trans-Anglo Books, 1987).

⁴ A recent factsheet on Big Creek states that the system generates “about 1,000 megawatts” of power; “The Big Creek System,” Southern California Electric Company, n.d., accessed 2 May 2015, https://www.sce.com/NR/rdonlyres/3A43A44E-E788-4CAD-85EF-0AA8931C825A/0/FS_TheBigCreekSystem.pdf.

Today, more than a century after construction on the Big Creek system was begun, the magnitude of the effort that the designers, builders, and manual laborers invested in it remains astounding. At one point, hundreds of men were at work building a thirteen-mile-long tunnel through the mountains to connect a high-altitude lake to the powerhouses below. The reservoirs, tunnels, dams, powerhouses, and transmission lines were, moreover, only a small portion of the system that had to be constructed. As historian of technology Thomas P. Hughes argued in his classic *Networks of Power*, the success of early electric power systems depended both on technical achievements and on the heterogeneous engineering of society, culture, politics, and economics. Cultivating consumer interest, defending free enterprise, recruiting and disciplining workers, and selling the California dream were vital system-building activities for companies like Pacific Light & Power, which began the Big Creek project, and Southern California Edison, which has maintained and expanded it since 1917. It was this sociotechnical system in its entirety that made hydroelectric power generation and distribution possible.⁵

The environment too had to be woven into the seamless web for hydroelectric systems to function as intended.⁶ For one thing, topography and climate determined where power could be produced. When Big Creek's transmission lines were built, they were the world's longest at 241 miles; they were also among those with the highest voltage at 150,000 volts. California's leading role in the development of long-distance, high-voltage transmission was, Hughes argues, mainly due to its geography, since its major sources of exploitable "white coal" were hundreds of kilometers from consumers in San Francisco and Los Angeles. As I stand atop the dam that created Huntington Lake, the earliest of the Big Creek system's reservoirs, it is clear that the importance of the environment did not end with the siting of the dams or construction of transmission lines. Even to my untrained eye, the reservoir looks depleted after three years of drought. If water levels were to drop too far, the turbines in the powerhouses below would eventually slow to a standstill.⁷

The dependence of the Big Creek system on its topographical and climatological environment meant that it was not just a sociotechnical system; it was also, like the Rhône and

⁵ While Hughes focused on Pacific Gas & Electric, which was dominant in northern California, his conclusions apply equally well to Southern California Edison; Thomas P. Hughes, *Networks of Power: Electrification in Western Society* (Baltimore: Johns Hopkins University Press, 1983), 262-284; for an overview of his theoretical approach, see Thomas Parke Hughes, "The Evolution of Large Technological Systems," in *The Social Construction of Technological Systems: New Directions in the Sociology and History of Technology*, ed. Wiebe E. Bijker, Thomas Parke Hughes, and Trevor J. Pinch (Cambridge, Mass.: MIT Press), 51-82. The concept of "heterogeneous engineering" comes from John Law, 'Technology and Heterogeneous Engineering: the Case of the Portuguese Expansion', in Bijker, Hughes, and Pinch, *Social Construction of Technological Systems*, 111-134.

⁶ Thomas Hughes, "The Seamless Web: Technology, Science, Etcetera, Etcetera," *Social Studies of Science* 16, no. 2 (1986): 281-292.

⁷ While power generation continued unabated at the time of my visit, the High Sierra Regatta that normally takes place on Huntington Lake had recently been cancelled for the first time in six decades due to low water levels; Tim Sheehan, "High Sierra Regatta Canceled by Low Water at Huntington Lake," *Fresno Bee*, 2 April, 2014, <http://www.fresnobee.com/2014/04/02/3856414/high-sierra-regatta-canceled-by.html>.

other heavily engineered rivers, an envirotechnical system.⁸ One might even call the meltwater upon which the hydroelectric system depends part of its “natural infrastructure,” just as the forests and farms through which water runs into the Panama Canal eventually came to be seen as part of the infrastructure of that waterway in the twentieth century.⁹ The engineers involved with Big Creek were certainly aware of their ongoing dependence on what they called “nature”—that is, the nonhuman forces that impinged on the system from the outside. At the Huntington Library, I find a pamphlet that compares the operation of Big Creek to “playing chess with Nature,” inasmuch as fluctuating levels of precipitation and consumer demand from season to season and year to year required constant shifts in strategy.¹⁰ To stay a step ahead, Big Creek’s engineers built reservoirs, re-routed rivers, managed forests, seeded clouds, and kept a close eye on both the weather forecast and the price of power from alternative sources. Today, they also consider the possible long-term effects of climate change. None of this can be decided once and for all; like a game of chess, it requires nimble responses to unexpected moves.¹¹

Hughes defined the environment of a large technical system as “the influences and forces that affect, and are affected by, the system, but are not controlled by it,” and suggested that engineers spent much of their time trying to take control of such external influences and thereby incorporate them into the system.¹² But there are also things that engineers can do to make the system a little bit more manageable, the game a little more winnable, even when the environment remains beyond their control. They do so by building buffers between the environment and whatever infrastructure is in question, and by making the infrastructure more resilient to the disruptions that will nonetheless inevitably occur. These techniques can seem

⁸ Sara B. Pritchard, *Confluence: The Nature of Technology and the Remaking of the Rhône* (Cambridge, Mass.: Harvard University Press, 2011); see also Mark Cioc, *The Rhine: An Eco-Biography, 1815-2000* (Seattle: University of Washington Press, 2002); Richard White, *The Organic Machine* (New York: Hill and Wang, 1995).

⁹ Ashley Carse, “Nature as Infrastructure: Making and Managing the Panama Canal Watershed,” *Social Studies of Science* 42, no. 2 (2012): 539-563.

¹⁰ Charlie Peirson, “Playing Chess with Nature,” in *Edison Partners, Special Edition Relating to the Building of the New Electric Giant of the Pacific Coast*, 7 September, 1923, Folder 4: “S.C.E. Co., Big Creek, 1923,” Box 459, Southern California Edison Records, Huntington Library, San Marino, California (hereafter SCE Records), 11.

¹¹ Cloud seeding to enhance hydroelectric power production has been conducted continuously in the southern Sierra Nevada since the early 1950s; see California Department of Water Resources, “Precipitation Enhancement,” in *California Water Plan Update 2009 Vol. 2 – Resource Management Strategies*, California Department of Water Resources Bulletin 160-09, http://www.waterplan.water.ca.gov/docs/cwpu2009/0310final/v2c10_precipenhance_cwp2009.pdf. A 2009 study sponsored by the California Energy Commission concluded that power generation at Big Creek was not immediately threatened by climate change, but that a combination of reduced mountain runoff and increased late-summer heat waves might force changes in operation; Sebastian Vicuña, John A. Dracup, and Larry Dale, “Climate Change Impacts on the Operation of Two High-Elevation Hydropower Systems in California,” California Climate Change Center, August 2009, <http://www.energy.ca.gov/2009publications/CEC-500-2009-019/CEC-500-2009-019-F.PDF>.

¹² Hughes, “Seamless Web,” 270. Elsewhere Hughes wrote: “Those parts of the world that are not subject to a system’s control, but that influence the system, are called the environment”; Hughes, *Networks of Power*, 6.

mundane, even trivial in comparison to grand system-building efforts, but they are essential to producing the invisibility of the environment to the users of industrial infrastructures.¹³ In rich, industrialized societies, flipping on a light switch or turning on a faucet does not evoke fossil-fuel mining or hydrologic cycles, nor does it make visible the “shadow places” of commodification.¹⁴ The ability of power generation and distribution infrastructures to stay in the shadows is partly the result of small interventions that prevent their environments—which always remain, despite the ambitions of system-builders, unpredictable and uncontrollable—from disrupting the system’s function. In this way, animate infrastructures are able to withstand the living and nonliving agencies that are constantly working to destroy, dismantle, or reconfigure them.

Which brings us back to birds, and to the techniques of insulation and interconnection that prevented them and their excrement from shutting down an electric power system. While birds continue to be a significant concern for power companies today, and power lines have increasingly become a concern for those who wish to protect birds, birds have not seriously threatened the functioning of long-range power transmission in California since the 1920s. The story of why they have not provides some insight into questions at the intersection of technology and the environment: How, given their inevitable exposure to nonhuman forces and agents that always remain beyond human control or prediction, is it possible for large infrastructures to work at all, let alone as well as they sometimes do? How can the multifarious connections between human and nonhuman nature that industrialization has produced be as invisible to the average user as they actually are, at least in rich, industrialized societies? In short, how has it become so easy to forget that infrastructures have environments? Humble strategies of insulation and interconnection are, I would argue, an important part of the answer.

In the following narrative, I deploy certain tropes about the agency of assemblages and the vitality of nonhuman actors that have been developed by scholars seeking to articulate a new or vital materialism.¹⁵ While I find these tropes useful for calling attention to nonhuman and emergent agencies, I also seek to revise them in several ways. Wary of the tendency of some of this work to uncritically adopt natural-scientific understandings of materiality, I make no claims about the nature of materiality or “thing-power” as such.¹⁶ Electric power systems,

¹³ Sara B. Prichard and Thomas Zeller, “The Nature of Industrialization,” in *The Illusory Boundary: Environment and Technology in History*, ed. Martin Reuss and Stephen H. Cutcliffe (Charlottesville: University of Virginia Press, 2010), 69-100, 85. See also Jon Mooallem, “Squirrel Power!” *New York Times*, 31 August, 2013, accessed 15 May 2015, <http://www.nytimes.com/2013/09/01/opinion/sunday/squirrel-power.html>.

¹⁴ Val Plumwood, “Shadow Places and the Politics of Dwelling,” *Australian Humanities Review* 44, March (2008). See also Christopher F. Jones, “Building More Just Energy Infrastructure: Lessons from the Past,” *Science as Culture* 22, no. 2 (2013): 157-163.

¹⁵ Jane Bennett, *Vibrant Matter: A Political Ecology of Things* (Durham, NC: Duke University Press, 2010); Stacy Alaimo, *Bodily Natures: Science, Environment, and the Material Self* (Bloomington: Indiana University Press, 2010).

¹⁶ e.g., Jane Bennett, “The Agency of Assemblages and the North American Blackout,” *Public Culture* 17, no. 3 (2005): 445-465, 458; for a critique of the materiality of new materialism, see Heather Paxson and Stefan Helmreich, “The Perils and Promises of Microbial Abundance: Novel Natures and Model Ecosystems, from Artisanal Cheese to Alien Seas,” *Social Studies of Science* 44, no. 2 (2014): 165-193.

birds and their excrement, and amateur ornithologists and professional engineers are not inherently lively (or necessarily material, for that matter); they become so under conditions that cannot be deduced in advance. It is only after an actor begins to affect us that we can begin to search for the historically particular conditions that made it capable of doing so. Moreover, I question the idea that there is a necessary connection between attending to the animacy of things and assemblages and focusing on cases of indeterminacy or surprise. Like other living things, humans have developed a wide range of practices that stabilize, within the flux of changing relations, certain assemblages upon which our vitality depends. Given the ubiquity of change, the stabilization of such infrastructures of animacy is the necessary foundation for any enduring project. Insulation and interconnection are two strategies that have been developed to achieve the stabilization of certain systems that undergird human life today. By attending to these strategies of stabilization with the help of an idiom that calls our attention to nonhuman and more-than-human agencies, we can better understand not only why such infrastructures sometimes surprise us but also why, most of the time, they function precisely as we expect them to.

Bird Trouble

The first time that I get close to one of the Big Creek transmission towers on foot, it is the sound rather than the sight that is most affecting—a buzzing, seething crackle that seems both very lively and very deadly.¹⁷ That energy is very well contained within the thin conducting wires that carry it, but its power is nonetheless evident. Like a river, electricity is not a thing but rather an unruly process that can only be turned to human ends with great effort, and then only partially.¹⁸ When the transmission lines were first built in the early 1910s, even the engineers who designed them were not certain how they would behave under varying loads and environmental conditions. They conducted intensive research into the composition of the wires, the necessary spacing between the lines, and the use of various kinds of insulators to separate the lines from the transmission towers and from the ground. The successful operation of two 150,000-volt lines from Big Creek to the Los Angeles area beginning in 1913 did not indicate an end to electricity's surprises. In the early 1920s, Southern California Edison decided to upgrade the lines to 220,000 volts in order to carry the additional power generated by an expansion of the Big Creek system. Doing so would allow the company to meet the booming demand for electric power in the Los Angeles area without having to build new lines across the entire 241-mile span (Figure 2). But it also raised new questions and spurred an intensive bout of research in the attempt to answer them.¹⁹

¹⁷ The sound is produced by a phenomenon known as corona discharge, in which the air surrounding a conductor is ionized and becomes conductive. Audible noise is produced when current passes through the ionized air, causing it to expand rapidly. Because corona discharge can lead to power losses and service interruptions, it was the focus of intensive research by engineers in the electric power industry; see, e.g., F.W. Peek, Jr., "The Law of Corona and the Dielectric Strength of Air," *Transactions of the American Institute of Electrical Engineers* 30, no. 3 (1911): 1889-1965.

¹⁸ On the entanglement of human labor with natural forces, see White, *Organic Machine*. On the electric power system as an assemblage of human and nonhuman agencies, see Bennett, "Agency of Assemblages."

¹⁹ The decision to upgrade to 220,000 volts is described in Myers, *Iron Men and Copper Wires*, 118-119.

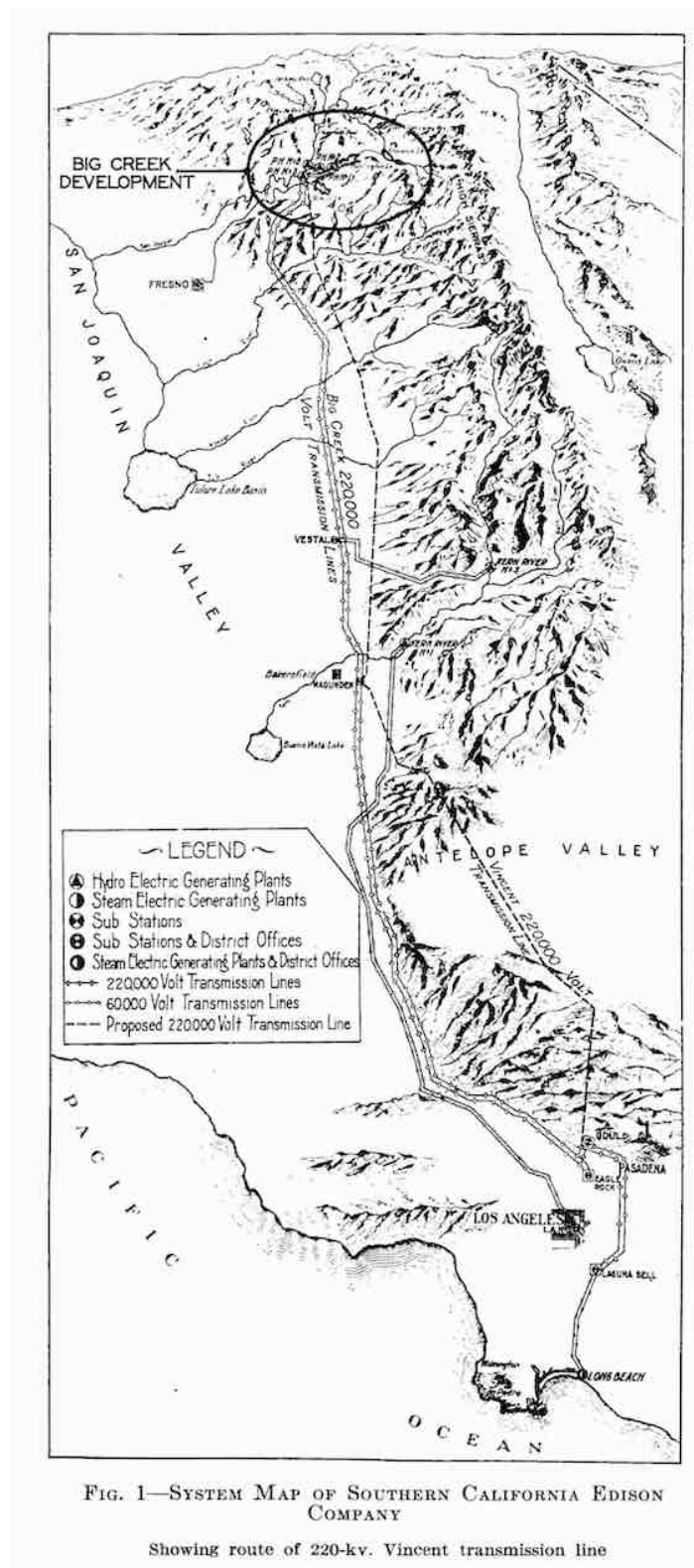

Figure 2. System map of Southern California Edison Company circa 1926. Source: C.B. Carlson and Harold Michener, "The Vincent 220-Kv. Transmission Line: Engineering and Construction Features," *Journal of the American Institute of Electrical Engineers* 45, no. 12 (1926): 1215-1229, on 1216. Reprinted with permission of the Institute of Electrical and Electronics Engineers.

Traveling along the length of the original Big Creek lines, I can still make out the joints where workers attached new bases to the towers, which needed to be raised for the switch to 220,000 volts. It is hard, though, to picture the landscape in which they labored. Although the Central Valley was already well on its way to becoming one of the most productive agricultural regions in the world, some features that define the landscape today—like the widespread electrification and mechanization of farming—were absent or only in their infancy.²⁰ Raising the height of most of the towers along the line was necessary in order to provide sufficient clearance between the higher-voltage lines and the ground. The crews also lengthened the strings of suspended insulators separating the lines from the towers in order to reduce the chance of flashovers—arcs of electric current that sometimes leapt beyond the wires to flow through the steel towers and into the earth, short-circuiting the entire transmission system. As the transmission voltage increased, so did the ease with which flashovers occurred. Incredibly, the crews did this work while the lines were still energized, since the company could not afford to interrupt the connection to its most important generating source. Despite these challenges, the renovation was completed without major incident and the switchover to 220,000 volts took place in May 1923.²¹

Within a few months of operating at the higher voltage, however, a spate of unexplained flashovers threatened to transform engineering triumph into failure. Flashovers and their causes were among the main preoccupations of transmission-line engineers, since the diversion of electrical current into the earth could disrupt the entire transmission system and severely damage equipment at powerhouses and substations. The standard response to a flashover was to lower the voltage of the transmission line until the arc was broken and then to bring the voltage back up, on the assumption that the conditions that had led to the flashover were transient and the line would resume its normal operation. Depending on the severity of the flashover and the state of the system, the process of lowering and raising the voltage could produce either a noticeable voltage drop or an actual power outage for users in Los Angeles lasting anywhere from a few seconds to a few minutes. When the number of flashovers on the Big Creek lines grew to 12 in July and 14 in August of 1923, resulting in an interruption every two or three days on average, the need for a lasting solution became urgent.²²

²⁰ On the agricultural industrialization of the Central Valley and its ecological and health consequences, see Stoll, *Fruits of Natural Advantage*; Linda Nash, *Inescapable Ecologies: A History of Environment, Disease, and Knowledge* (Berkeley: University of California Press, 2006); David Igler, *Industrial Cowboys: Miller & Lux and the Transformation of the Far West, 1850-1920* (Berkeley: University of California Press, 2001); Andrew C. Isenberg, *Mining California: An Ecological History* (New York: Hill and Wang, 2005); Donald Worster, *Rivers of Empire: Water, Aridity, and the Growth of the American West* (New York: Oxford University Press, 1985), esp. 96-110.

²¹ The process of raising the towers and otherwise retrofitting the lines for 220,000 volts is described in H. A. McIntosh, "Changing Lines to 220,000 While Hot," *Electrical World* 82, no. 14 October (1923): 695-697. More technical details can be found in a series of articles published together as "Transmission at 220 Kv. on the Southern California Edison System: A Symposium," *Transactions of the American Institute of Electrical Engineers* 43 (1924): 1222-1237.

²² Harold Michener, "Description of the System and Operating Experiences," *Journal of the American Institute of Electrical Engineers* 43, no. 10 (1924): 1222-1225; Harold Michener, "Where Engineer and Ornithologist Meet: Transmission Line Troubles Caused by Birds," *Condor* 30, no. 3 (1928): 169-175;

Harold Michener was one of the Southern California Edison engineers responsible for finding a solution to the mysterious flashovers on the upgraded lines, and it is his writings that are partly responsible for bringing me to Southern California. I imagine that the summer and fall of 1923 were a time of intense pressure for him and his fellow engineers. Looking back on this time, Michener later noted that if “the higher numbers which prevailed during the summer of 1923 had continued, the operation at 220,000 volts would have been pronounced a failure, the consumers could not have endured such frequent interruptions, and not only this project, but high voltage transmission in general would have received a severe set-back.”²³ There is perhaps a touch of exaggeration here, but not much; Southern California Edison was pushing the limits of what was thought to be possible with the technology of the day, and its ability to assure both commercial and residential customers of the reliability of electric power was essential to expanding the market and earning back its investment.²⁴

In addition to his day job as a transmission-line engineer, Michener was also one of Southern California’s leading amateur ornithologists. Over the course of his life, he banded tens of thousands of birds and published a number of studies of bird behavior and migration in scientific journals. His banding work was part of a federally supported program that sought to map the migration paths of birds so that they could be more effectively managed, but it also provided opportunities for Michener and other amateurs to become intimately acquainted with the individual birds they handled, some of whom were recaptured year after year. Most of his research was conducted in partnership with his wife Josephine R. Michener, who had studied zoology at the University of California, worked for several years in a biological laboratory before their marriage, and had an independent reputation as a thorough and astute student of birds. Though her name appears nowhere in her husband’s publications on power lines, it seems likely that her biological training influenced Harold Michener’s approach to understanding the problem. Together, they helped established Southern California as a regional center of ornithological expertise that was at least partly independent of the great museums and universities to the east.²⁵

In the 1920s, the unexplained flashovers on the new 220,000-volt lines brought Harold Michener’s professional and amateur interests together in an unexpected way. By that time, it was already well known to electric power engineers that birds could pose problems for transmission lines and other equipment. As a headline in Southern California Edison company newsletter noted a few decades later, when it came to electric power, “Birds and Trouble Are

R. J. C. Wood, “220-Kv. Transmission Transients and Flashovers,” *Journal of the American Institute of Electrical Engineers* 44, no. 11 (1925): 1211-1218, 1211.

²³ Michener, “Where Engineer and Ornithologist Meet,” 173.

²⁴ In 1923, Southern California Edison estimated that its investment in the Big Creek expansion and in its transmission and distribution system would cost about \$200 million over the next decade; “Southern California Edison Plans New Capitalization,” *Electrical World* 82, no. 5, 4 August (1923): 245.

²⁵ On the Micheners’ ornithological work, see “Harold Michener, 1882-1949,” *Condor* 52, March (1950): 95; “Obituary: Josephine R. Michener,” *Condor* 73, no. 2 (1971): 256. On the history of ornithology and bird-banding in the United States, see Mark V. Barrow, Jr., *A Passion for Birds: American Ornithology after Audubon* (Princeton, NJ: Princeton University Press, 1998), 171-172; Robert M. Wilson, *Seeking Refuge: Birds and Landscapes of the Pacific Flyway* (Seattle: University of Washington Press, 2010), 73-74.

Synonymous.²⁶ As early as 1915, Southern California Edison's predecessor, the Pacific Light & Power Corporation, had installed vertical rods above the central insulators on the Big Creek transmission towers in order to discourage birds from perching, and thereby to reduce the accumulation of bird "dirt" on the insulators, which was known to be a potential source of flashovers, particularly under conditions of high humidity. In such cases, the source of the flashover could usually be identified post hoc by looking for the remains of excrement on the insulators or for the body of the bird, which was often found partly charred at the base of the tower.

None of these signs, however, seemed to be present in the case of the mysterious flashovers on the new 220,000-volt lines, which initially led Southern California Edison's engineers to dismiss birds as a possible cause. Alternative explanations were myriad and wildly speculative; they included voltage surges due to line switching or lightning strikes, moisture on the spider webs that accumulated on towers, poorly understood voltage fluctuations across the insulator units closest to the conducting wires, or the formation of "rivers of ions" in the air around the insulators, which might be displaced by the wind until they made contact with the tower.²⁷ "These theories were not promulgated by the lowly," Michener later recalled, "but by some of the very best minds in the profession."²⁸ Research on the causes of flashovers was hindered by the fact that each transmission system faced a unique combination of technical and environmental conditions. Lightning and sleet, for example, were major problems in the northeastern United States but relatively insignificant in Southern California.²⁹ Moreover, causes that were innocuous in isolation could become problematic when combined with other factors. Accumulated dust and bird "dirt" might not lead to flashovers when the lines were dry, for example, but could cause problems when combined with heavy fog, rain, or salt spray.³⁰

It was only the chance observation, by one of the men in charge of the Big Creek transmission line, of an eagle leaving behind a string of excrement as it launched from a tower that lent weight to theory that so-called bird "streamers" might cause flashovers. Like the term "bird dirt," "bird streamers" was a euphemism for the jets of excrement that birds often released as they launched from their perches on transmission towers. In contrast to accumulated "dirt," the highly conductive streamers were capable of initiating a flashover simply by coming close to, rather than actually touching, the tower and the line. Because the streamers themselves were destroyed by the concentrated energy of the arc, such flashovers often left no observable traces. Tests run by engineer R.J.C. Wood in Southern California

²⁶ "Birds and Trouble Are Synonymous," [Southern California] *Edison News* 2, no. 5, May (1943): 3, in Folder 3: "Edison News, 1943," Box 309, SCE Records.

²⁷ Michener, "Where Engineer and Ornithologist Meet," 169-70.

²⁸ *Ibid.*, 170.

²⁹ In the SCE Records I find a book on overhead line construction that includes an entire section of meteorological data drawn from the U.S. Weather Service, including a map of the "Sleet Storm Area" in the northeastern United States; Sub-Committee on Overhead Line Construction of the National Electric Light Association, *Handbook on Overhead Line Construction*, 3rd ed (New York: National Electric Light Association, 1917), map on 180, in Folder 2: "Edison Library Books, Transmission and Overhead Lines, Handbook on Overhead Line Construction, 1914," Box 368, SCE Records.

³⁰ A. O. Austin, "The High Efficiency Suspension Insulator," *Proceedings of the American Institute of Electrical Engineers* 30, no. 6 (1911): 1319-1344; R. J. C. Wood, "Spray and Fog Tests on 220-Kv. Insulators," *Journal of the American Institute of Electrical Engineers* 48, no. 12 (1929): 900-904.

Edison's high-voltage laboratory, in which a solution of starch and salt was released suddenly from a small tube showed that it was theoretically possible for a bird streamer to trigger a flashover.³¹ Whether the same would happen with real excrement on real transmission towers remained unclear. Only the reduction in flashovers that resulted from the installation of bird guards and deterrents on Big Creek's transmission lines eventually settled the question definitively.

However fascinated Michener may have been with birds for their own sakes, the transmission-line engineer in him seems to have seen them as just one of many external influences that could disrupt reliable service. His approach to power lines and birds suggests the relational aspect of infrastructure: as one thing came into the foreground, something else faded into invisibility.³² In his published writings on the issue, both in trade magazines and in the *Condor*, California's preeminent ornithological journal, Michener seems entirely focused on the reliability of the electric-power system. As he and one of his fellow engineers later wrote, birds were among the "natural and artificial agencies that might interfere with operation" of an electrical system, along with "forest fires, wind storms, lightning, sleet, floods, airplanes, and portable derricks."³³ That is, they were part of the dangerous and unpredictable environment through which transmission lines had to travel to reach their ultimate destinations. Caring for the infrastructure meant suppressing, at least for the moment, concern for the entities who threatened its integrity.

If balancing water levels in Big Creek's reservoirs with projected demand was playing chess with Nature, preventing bird excrement from causing flashovers was a humbler game, but nonetheless a serious one. The transmission-line engineers, the patrolmen who monitored the lines, and the powerhouse and substation operators responsible for responding to flashovers could not pretend that the electric power grid was independent of nature or the environment. A three-year drought and the excrement of a few dozen raptors both had the potential to interrupt service to thousands of customers, albeit in very different ways. Ultimately, of course, neither drought nor hawks brought the system down. On the contrary, over the years, the Big Creek system, like the California power grid of which it was a part, became increasingly powerful and reliable. Only under extraordinary circumstances were consumers reminded of the remarkable chain of circumstances that made the delivery of hydroelectric power across such vast distances possible: the melting snows that gathered in mountain reservoirs, the generating stations that pushed and pulled electrons along hundreds of miles of wire, and the expensive devices and labor-intensive practices that kept birds from accidentally re-routing that power into the earth.

Two key interventions made it so easy for the consumers of electric power to forget that the system was dependent on and vulnerable to its environment. The first was insulation. I mean this both in the literal sense of the use of non-conducting material to separate electrical conductors from each other and from the ground, and in the more general sense of separating,

³¹ Michener, "Description of the System and Operating Experiences," 1224-1225.

³² Susan Leigh Star and Karen Ruhleder, "Steps toward an Ecology of Infrastructure: Design and Access for Large Information Spaces," *Information Systems Research* 7, no. 1 (1996): 111-134.

³³ Mabel Macferran and Harold Michener, "High-Voltage Transmission of Power," *The LOG*, Jan. 1930, 25-28, 25-26, in Folder 3: "S.C.E. Co., Transmission, 1922-1968," Box 475, SCE Records.

detaching, or disconnecting, i.e., of making insular. The horizontal metal pans that Michener and his colleagues designed to catch falling bird excrement before it neared the transmission lines were just as much insulators, in this sense, as the strings of ceramic units that separated the transmission lines from the towers. The second intervention was interconnection, which again I mean in both a literal sense of connecting together transmission systems—the sense in which electrical engineers used the term—and in a more general sense of strengthening the internal relationships that made the system resilient to disruption.³⁴ When engineers designed and built new switching stations that linked together previously separate power grids, implemented relays that automatically shifted load away from lines where flashovers had occurred, or trained substation operators to respond more quickly to service interruptions, they were also practising forms of interconnection. Whereas insulation protected the system from the vagaries of its environment, interconnection made it resilient to those interruptions that could not be prevented. These two strategies have been crucial to establishing the invisibility of the environment of electric power grids and other industrial infrastructures.³⁵

Insulation

At the top of one of the Big Creek system's transmission towers, outside what looks like a poultry farm east of Fresno, a red-tailed hawk swoops in for a landing, talons outstretched to grasp the tower's topmost beam (Figure 3). Standing near the fenced-off entrance to the property, I can just make out a series of long, low buildings where the poultry seem to be kept. This too, is a kind of animate infrastructure, buffered against the external actors who seek to appropriate it into their own infrastructures of consumption and networked into a distributed, interconnected, partially redundant industrial food system.³⁶ For the hawk to be lingering here, there must be other, wilder prey nearby. A few feet directly below the hawk are strings of ceramic insulators, and between the hawk and the insulators is a wide horizontal pan made of metal. On a nearby tower, there is no horizontal pan, but the insulators are shielded from above by a kind of tent made of stiff, transparent plastic. On this tower, the topmost beams are also partly covered with narrow, sawtoothed sheets of metal that have been carefully placed to discourage perching above the outermost strings of insulators. Like a barbed-wire fence meant to divide the wild from the domesticated, these forbidding spikes embody both a material and conceptual border.³⁷

³⁴ Within the electric industry, the term "interconnection" was typically used to refer to the creation of unified regional power grids via interties between the grids of individual companies or public utilities. An example of the standard use of the term can be found in this article proposing the construction of a 220,000-volt backbone connecting all of California's grids: R.W. Sorenson, H. H. Cox, and G. E. Armstrong, "California 220,000-volt-1100-Mile-1,500,000-kw. Transmission Bus," *Proceedings of the American Institute of Electrical Engineers* 38, no. 9 (1919): 1027-1038.

³⁵ Pritchard and Zeller, "Nature of Industrialization," 72.

³⁶ The history of intensive chicken production is described in Roger Horowitz, "Making the Chicken of Tomorrow: Reworking Poultry as Commodities and as Creatures, 1945-1990," in *Industrializing Organisms: Introducing Evolutionary History*, ed. Philip Scranton and Susan Schepfer (New York: Routledge, 2004), 215-235.

³⁷ For a moving reckoning with the human and nonhuman costs of barbed wire as a technology of confinement, see Reviel Netz, *Barbed Wire: An Ecology of Modernity* (Middeltown, Conn.: Wesleyan University Press, 2004).



Figure 3. A red-tailed hawk landing on one of the Big Creek transmission towers near Sanger, California. Photograph by author.

The red-tail flies off the tower after only a few minutes, but a pair of crows are soon squabbling in his or her place. The tower on which they are perched supports one of two parallel lines from Big Creek to the Eagle Rock substation near Pasadena. Each line consists of three wires, each of which carries alternating current at 220,000 volts and 60 cycles per second. (For reasons that exceed my grasp of electromagnetism, circuits composed of three wires are apparently better than two for electric power distribution.)³⁸ As I have learned from the Huntington Library's collection of Southern California Edison photographs and other sources, the pans and spikes that are visible on the towers have been in use since the 1910s or 1920s to minimize the impact of birds on electric power transmission. They are what one might call bioinsulators: devices and practices meant to isolate the system from its living environment. Such forms of insulation are essential to the existence of autonomous organisms;

³⁸ Southern California Edison's lines originally ran at 50 Hertz, or 50 cycles per second, but were switched to 60 Hertz in 1948 in order to simplify interconnection with other systems; H. W. Tice, A. A. Kroneberg, W. N. Johnson, J. D. Enefer, E. E. Tugby, and C. L. Sidway, "A System Frequency Change," *Electrical Engineering* 67, no. 9 (1948): 866-881.

they are what make possible the distinction between an external environment and an interior milieu.³⁹ They are just as essential to the life of animate infrastructures.

That such forms of insulation against bird life would be necessary was not, however, immediately apparent to Michener or the engineers of California's long-distance transmission systems. It only emerged as the result of an iterative process of failure, investigation, and experimentation. The first important step was the development of so-called suspension insulators as a replacement for pin-type insulators, in which the conducting wire sat on top of a ceramic insulator unit affixed to a crossbeam. While pin-type insulators were simple in design and effective under ideal conditions, they turned out to be both highly deadly and highly vulnerable in the field, since the distance between the conducting wire and the tower was short enough for even small objects—including the bodies of small birds—to establish a short-circuit. Suspension insulators were a significant improvement; they consisted of strings of individual ceramic insulating units that hung below the crossbeam, with the conducting wire attached at the bottom of the lowest unit. With more distance between the wire and the tower, flashovers of all kinds became less likely.⁴⁰ Suspension insulators also had the advantage that they could easily be lengthened to increase insulation, as was done for the Big Creek line as part of the 220,000-volt upgrade.

The switch to suspension insulators was only the beginning, however, of a long battle to prevent birds from interfering with power transmission. Because suspension insulators hung below crossbeams that made for attractive perches, they remained vulnerable to the accumulation of bird "dirt," which reduced the resistance of the insulators and increased the probability of flashovers. In 1915, in response to the problem of birds roosting above and excreting on the central insulator strings, Pacific Light & Power installed bird barriers on some of its transmission towers. It is unclear how many towers were thus equipped; perhaps only a few. The barriers consisted of a row of vertically oriented metal rods located on the top beam of the tower, or on the beams that directly supported the insulator strings. Given the ample space between the rods that can be seen in a series of photographs from 1915, they do not seem likely to have been very effective at preventing birds from perching.⁴¹ Nonetheless, from 1913 to 1923, the number of flashovers on the Big Creek lines from all causes averaged only about 16 per year—enough to cause occasional headaches for system operators, but not enough to justify expensive efforts to prevent them.⁴²

³⁹ On the history of the concept of interior milieu, see Frederic L. Holmes, "Claude Bernard, The 'Milieu Intérieur,' and Regulatory Physiology," *History and Philosophy of the Life Sciences* 8, no. 1 (1986): 3-25.

⁴⁰ The vulnerability of pin-type insulators to being short-circuited by birds was recognized by engineers for Southern California Edison as early as 1911; see comments of B. F. Pearson in "Operation of Transmission Systems," *Electrical World* 57, no. 22, 1 June (1911): 1423-1425, 1424.

⁴¹ The bird barriers are visible in several photographs in the Huntington Digital Library collection of Southern California Edison photographs, including "Big Creek Transmission Line," 21 March, 1915, Image Number SCE_03_00700, accessed 2 May 2015, <http://hdl.huntington.org/cdm/singleitem/collection/p16003coll2/id/1266/rec/13>, and "Big Creek Transmission Line," 21 March, 1915, Image number: SCE_03_00698, accessed 2 May 2015, <http://hdl.huntington.org/cdm/singleitem/collection/p16003coll2/id/1278/rec/10>.

⁴² Michener, "Description of the System and Operating Experiences," 1223.

In 1923, however, the massive increase in flashovers—31 in the period from June to August alone—posed a more serious threat to the operation of the system. Like the earlier bird barriers, the first bird guards installed in response to the 1923 crisis aimed to prevent large birds from roosting immediately above the tower's central string of insulators.⁴³ Far from decreasing the rate of flashovers, however, this intervention actually seemed to increase them. Unable to perch in their accustomed locations, the birds moved even closer to the insulators, often perching on the so-called shield rings that had been installed to protect the insulator units closest to the conducting wires from high voltages. As Wood noted a few years later, he and his colleagues had underestimated not only the distance across which an intact bird streamer could be blown by the wind but also what he described as the bird's "intelligence": "He had used that tower for a roost and observation point for years and looked upon any effort to oust him as an invasion of his rights, and he proved quite clever in surmounting the difficulties first put in his way."⁴⁴

Wood's comment on bird intelligence suggests the intimate if also often brutal engagement with the vitality of nonhuman actors that was required to bring such technical systems into operation. Unlike certain other aspects of the environment—the alpine streams that fed Big Creek's reservoirs, say, or the weather patterns that fed the streams—birds dynamically adapted to human interventions in pursuit of their own goals. In a largely treeless but prey-rich landscape such as that of the Central Valley, transmission-line towers provided unparalleled affordances for raptors, who could use them to rest and search for rodents, birds, and other prey in the fields below. For the purposes of a red-tailed hawk, just as for the Southern California Edison Company, the towers were a kind of infrastructure. Many human-built infrastructures live such double lives, simultaneously serving the purpose for which they were designed and being incorporated into alternative ways of life. Such human and nonhuman appropriations can have effects that ripple outwards, transforming the ecosystems, societies, and infrastructures around them.⁴⁵

Confronted with the birds' intelligence and adaptability, Southern California Edison engineers developed two new solutions that were ultimately more successful. Recognizing that birds could not be deterred from perching above the central cable's insulators—at least not in any cost-effective manner—they instead decided to install four-by-eight-foot sheet-iron pans to "catch the droppings from the birds on the central portion of the tower top, their most favored perch."⁴⁶ While effective, these pans had two disadvantages: at \$12.00 per tower they were seen as too expensive to install on all of the towers making up the transmission system, and they did nothing to protect the two wires at the outer edges of the towers. To solve these

⁴³ Michener, "Where Engineer and Ornithologist Meet," 174; Michener, "Description of the System and Operating Experiences," 1225.

⁴⁴ Wood, "220-Kv. Transmission Transients and Flashovers," 1211.

⁴⁵ Ecologists often interpret such infrastructural appropriations and their aftereffects as signs of ecological damage; see, e.g., in the case of artificial light, Travis Longcore and Catherine Rich, "Ecological Light Pollution," *Frontiers in Ecology and the Environment* 2, no. 4 (2004): 191-198.

⁴⁶ C. B. Carlson and Harold Michener, "The Vincent 220-Kv. Transmission Line: Engineering and Construction Features," *Journal of the American Institute of Electrical Engineers* 45, no. 12 (1926): 1215-1229, 1225.

problems, four-foot lengths of thin galvanized iron, cut into a forbidding three-inch-high sawtooth pattern, were attached to the outer crossbeams (Figure 4). At the same time, the shield guards at the top of the insulator strings were removed, having proven not only unnecessary for protecting the insulators from high voltages but actually harmful, since they made for attractive perches. When it subsequently became clear that neither the pans nor the spikes alone sufficed, both were installed on most of the towers despite the expense.⁴⁷



Figure 4. Spikes on the outer crossarms of one of the Big Creek transmission towers in the Central Valley of the kind that were first installed in 1924. The edge of a horizontal steel pan meant to catch bird excrement can be seen at the left. The smaller spikes on the crossbar above the central wire at the upper left of the image are a more recent innovation. Photograph by author.

This combination of perch-detering spikes and excrement-catching pans was first installed early in 1924 on the two upgraded parallel lines running from Big Creek to the Eagle Rock substation; flashovers subsequently declined to pre-upgrade levels. In the following decades, engineers for Southern California Edison continued to see these measures as both effective and necessary.⁴⁸ The company later installed similar spikes and pans not only on an entirely new 220,000-volt Big Creek line built in 1928, the so-called Vincent line, but also on

⁴⁷ Michener, "Description of the System and Operating Experiences," 1225; Michener, "Where Engineer and Ornithologist Meet," 174-175.

⁴⁸ Michener, "Where Engineer and Ornithologist Meet," 174.

its transmission line from the Hoover Dam in Nevada to Los Angeles, which was completed in 1939.⁴⁹ The result of the successful use of bird guards was that the various theories that had been proposed when the “mysterious” flashovers first made their appearance, from moist spider webs to wind-blown rivers of ions, were abandoned. By 1925, Wood could confidently write that the “search for abnormal and startling effects has been distressingly unsatisfactory from a spectacular point of view, but most reassuring to those who contemplate the use of high voltages for transmission.”⁵⁰ That is, it was not some mysterious and spectacular new electrical phenomena, as yet undiscovered by scientists, that was to blame for the flashovers, but rather something far more mundane: bird shit.

The fact that I can safely stand so close to the buzzing, crackling Big Creek transmission lines, and that birds can perch nearby on the towers and even on the lines themselves, is a consequence of the effective engineering of environmental insulation, which buffers the infrastructure from its living (and non-living) environment. So too is the fact that there are places that birds are prevented from standing, and places where, if they do stand, their excrement will be safely collected in metal pans or on plastic tents that prevent it from falling near the conducting wires. This kind of bioinsulation, when successfully implemented, allows us to forget about the electricity surging within those lines, to act as if the lines are effectively inert: nothing but conduits to deliver energy to distant consumers, or a perch for the birds. All infrastructural systems include some insulation of this sort: techniques and strategies that do not seek to incorporate the environment or the nonhuman forces and agents within it into the system, but simply to put a little space between them.

Nonetheless, despite their success, the practices of insulation that were implemented by Southern California Edison in the 1920s were not alone capable of producing the reliability of service that consumers had come to expect, and which eventually made it possible to forget almost entirely the nonhuman forces and materials of which the electrical system was made and in which it was embedded. The environment was too unpredictable and the cost of insulation was too high to entirely prevent unwanted intrusions from the environment into the system. To deal with those inevitable interruptions, Southern California Edison engineers employed a second strategy for making nature invisible: interconnection.

Interconnection

I am driving a zigzag route along the eastern edge of the southern Central Valley, trying to stay within sight of the two original Big Creek lines, which often cut obliquely across the rectangular road grid. Despite my effort to stay focused on the distinctive, paired towers, I am continually being distracted by the many other distribution and transmission lines that are strung across the valley, some serving local users and others destined for far-off clients in California’s coastal cities. In their very ubiquity, the lines become virtually invisible, or at least difficult to keep at the center of my attention. If infrastructure is inherently relational, then my relation to these power lines keeps changing: at one moment they stand in the foreground as

⁴⁹ Carlson and Michener, “The Vincent 220-Kv. Transmission Line,” 1224-1225; Harold Michener, “The Edison Line From Boulder Dam,” *Electrical Engineering* 58, no. 11 (1939), 463-465, 465.

⁵⁰ R. J. C. Wood, “220-Kv. Transmission Transients and Flashovers,” *Journal of the American Institute of Electrical Engineers* 44, no. 11 November (1925): 1211-1219, 1218.

one of my ends, in the next they fade into the background as just another condition of possibility, like the roads on which I am driving. Infrastructural inversion—the analytic practice of bringing the background into the foreground—requires a kind of focus that often escapes me in the course of two long days of driving.⁵¹

Before the system went online in 1913 at 150,000 volts, Pacific Light & Power had already decided that it would need two transmission lines running from Big Creek to Eagle Rock. The main reason to build two lines rather than one was to have enough capacity to transmit all of the power generated at Big Creek without using a voltage higher than 150,000 volts, which at the time was at the upper end of the range of voltages used for long-distance transmission. Building two lines had a secondary advantage in that damage to either one of the lines would not entirely cut off power transmission. Enough excess capacity was available that when a flashover occurred on one of the lines, the other line could take over until the arc on the first line had been broken.⁵² This was interconnection at its most minimal: two lines and a switch. But interconnection meant much more; it was also a set of practices and standards that made it possible for different components of the system—human and nonhuman, technical and natural—to work seamlessly together. For most users, California's power grid faded into the infrastructural background not only because it was well insulated, but also because when one part of the system went down, other parts were able to take up the slack.

As the Big Creek system grew in generating capacity, so did the redundancy and complexity of the system. In 1921, the Kern River hydroelectric plant, located near the southernmost reaches of the Sierra Nevada, was incorporated into the Big Creek transmission system. Power generated there was transmitted over 75,000-volt lines to the Vestal substation, where it was transformed to 220,000 volts and fed into the main Big Creek lines toward Eagle Rock. Between the Vestal and Eagle Rock substations lay the Magunden switching station, where power could be rerouted between the two main parallel lines. Finally, a new branch transmission line was constructed as part of the 1923 upgrade to 220,000 volts, which routed some of the power from the main transmission lines north of Los Angeles to the new Laguna Bell substation, which was located near important industrial users on the southwest side of the city.⁵³ These new facilities made the system both more redundant and more segmented, so that individual portions of the line—from Big Creek to Vestal, say, or from Vestal to Magunden—could be isolated when flashovers occurred (Figure 5).

⁵¹ Star and Ruhleder, "Steps toward an Ecology of Infrastructure"; Geoffrey C. Bowker, *Science on the Run: Information Management and Industrial Geophysics at Schlumberger, 1920-1940* (Cambridge, Mass.: MIT Press, 1994).

⁵² Edward Woodbury, "150,000-Volt Transmission System: Some Operating Characteristics of the Big Creek Development of the Pacific Light & Power Corporation," *Proceedings of the American Institute of Electrical Engineers* 33, no. 9 (1914): 1359-1370.

⁵³ "Laguna Bell Substation," *Electrical World* 81, no. 13, 31 March (1923): 766.

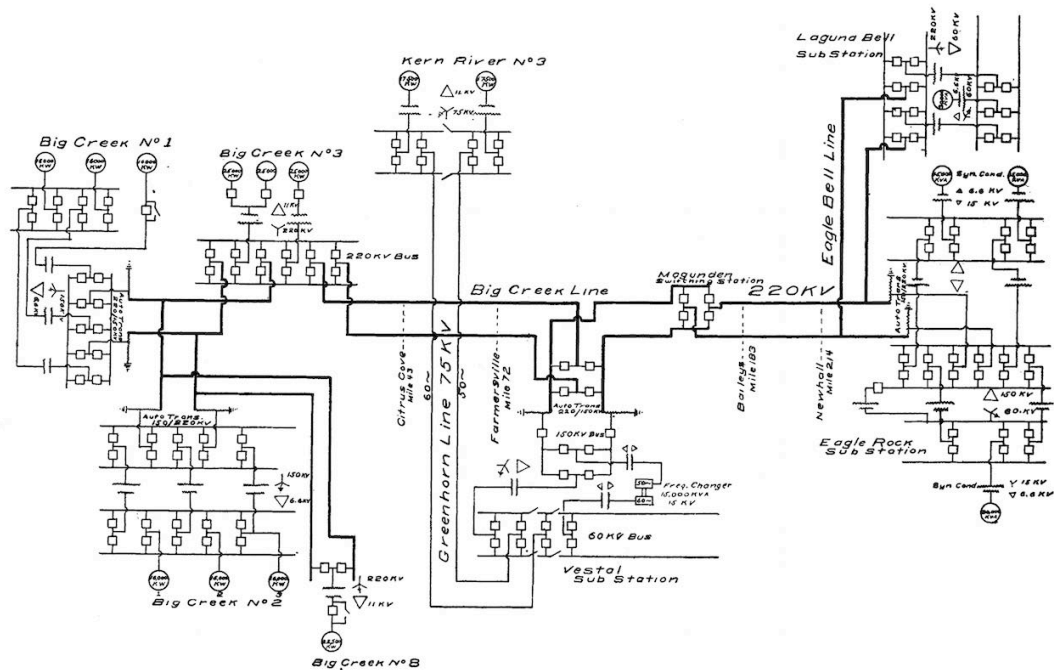

FIG. 1—SINGLE LINE DIAGRAM OF THE 220,000-VOLT SYSTEM OF THE SOUTHERN CALIFORNIA EDISON CO.

Figure 5. Schematic diagram of the Big Creek system circa 1924. Source: Harold Michener, "Description of System and Operating Experiences," *Transactions of the American Institute of Electrical Engineers* 43 (1924): 1222-1225, on 1223. Reprinted with permission of the Institute of Electrical and Electronics Engineers.

Given the ubiquity of power lines and the reliability of electrical service in California today, it might seem that increasing the number of redundant, interconnected, segmented lines would increase resilience in the face of localized disruption. In 1923, however, the immediate effect of the increased complexity and redundancy of the system was actually a temporary reduction in stability. Until then, operators had responded manually to flashovers by lowering the voltage on the affected line when alarms indicated a flashover and then bringing it up again once the arc had been cleared. At the same time, operators at Eagle Rock and the other receiving stations had to make adjustments to account for the drop in voltage. As the system became more complex, so did the process of lowering and raising the voltage and coordinating responses at the generating and receiving stations, which resulted in ever-longer outages. The slowing manual response times that resulted from an increasingly complex system thus exacerbated the effect of the unprecedented number of flashovers in the summer of 1923.

One response to this crisis was an all-out effort to prevent flashovers by improving the insulation of the lines. The installation of bird guards ultimately succeeded in bringing the frequency of flashovers down to about the level it had been with the 150,00-volt lines in Big Creek's first decade of operation, but not much further.⁵⁴ In 1924, Michener was optimistic that the newly installed bird guards would "eliminate nearly all flashovers," but by 1928 he was forced to admit that bird-caused flashovers, while drastically reduced, "will probably not be

⁵⁴ Wood, "220-Kv. Transmission Transients and Flashovers," 1211.

stopped entirely.”⁵⁵ As Michener and fellow Southern California Edison engineer Mabel Macferran later noted, “it is not economically justifiable to carry the preventive measures to extremes, for then electricity would be far from the cheap commodity it is at the present time.”⁵⁶ Installing the bird guards for the two original Big Creek lines alone had cost about \$100,000, the rough equivalent of about \$1.3 million today.⁵⁷

Faced with the practical and theoretical limits of insulation, engineers turned to interconnection, which involved not merely adding redundant lines to the system but also automating the process of responding to flashovers and other interruptions. Automatic relays were installed that isolated problematic sections of the line, switched load between lines, cleared flashovers, and restored voltage to its normal levels. Moreover, the two main 220,000-volt lines were each divided into subsections by the Magunden switching station and the new Vestal substation. When a flashover occurred on any of these sections, relays automatically detected the imbalance in current that resulted and cut off the problem section from the rest of the system, rerouting power as necessary. Because cutting off both lines simultaneously could lead to a catastrophic rise in voltage—which could damage or destroy equipment at the powerhouses and substations—the second line automatically shifted to manual operation if the other line was disconnected for any reason. To prevent extended service interruptions in such cases, a separate set of relays was installed that automatically lowered the voltage until a flashover was broken. Once the flashover had been eliminated, the press of a single button released a master relay and began the process of raising the voltage to its normal level.⁵⁸

After these relays and switches had been installed and the operators at the generating plants and substations had been trained in their use, response times improved so dramatically that a flashover that might have led to a significant outage in 1923 came and went with virtually no effect on consumers. When the sectionalizing relays were in operation, a flashover might lead to a drop in voltage lasting for anywhere from two to five seconds. When the relays had to be disabled—in cases when parts of the system were undergoing repair, for instance, or in the rare case that the other line had also been disabled by a flashover—the total procedure might take 30 seconds.⁵⁹ After about two years of operation under the new system, Wood confidently concluded that the “commercial significance to service of the flashovers has become a vanishing quantity now that reliable automatic relays are in use, provided duplicate sectionalized lines are available which will not be overloaded upon the loss of a section.”⁶⁰

Since flashovers continued to destabilize the system, bird guards continued to be installed, but the strategy of interconnection had guaranteed that such interruptions no longer posed a serious threat to the steady, reliable operation of the electrical system. It made the system more resilient to fluctuations in production and transmission capacity and in consumer

⁵⁵ Michener, “Description of the System and Operating Experiences,” 1225; Michener, “Where Engineer and Ornithologist Meet,” 175.

⁵⁶ Macferran and Michener, “High-Voltage Transmission of Power,” 26.

⁵⁷ Michener, “Where Engineer and Ornithologist Meet,” 175. I calculated the inflation-adjusted equivalent for the 1923 sum in 2014 dollars using the CPI (Consumer Price Index) Inflation Calculator of the U.S. Bureau of Labor Statistics, available at <http://data.bls.gov/cgi-bin/cpicalc.pl>.

⁵⁸ E. R. Stauffacher, “Automatic Protection—Balanced Relays and Flashover Control,” *Journal of the American Institute of Electrical Engineers* 43, no. 10 (1924): 1225-1228.

⁵⁹ Stauffacher, “Automatic Protection,” 1226-1227.

⁶⁰ Wood, “220-Kv. Transmission Transients and Flashovers,” 1211.

demand, and it did so not merely through redundancy but also through automation, which allowed the system to rapidly shift load between different parts of the grid and adapt to interruptions. This automation was partly electrical and partly social; it depended as much on the training and vigilance of operators as it did on the configuration of lines, relays, and switches. Interconnection also brought new risks; as the widespread blackout in eastern North America in 2003 showed, the more complex and interdependent the power system becomes, the less predictable the behavior of the system as a whole can be.⁶¹ Nonetheless, despite such eruptions of unexpected agency, the overall impact of interconnection was to bolster stability.



Figure 6. Eagle Rock Substation near Pasadena, California. The transmission lines from Big Creek are in the background running up the hill; lower-voltage distribution lines heading toward Los Angeles can just be seen at the lower left-hand corner of the image. Photograph by author.

⁶¹ Bennett, "The Agency of Assemblages." Part of what makes the failure of electrical systems so striking in rich, industrialized societies is that they are not generally perceived as fragile or high-risk; cf. Charles Perrow, *Normal Accidents: Living with High-Risk Technologies* (New York: Basic Books, 1984).

Embedded in lively environments, infrastructures must themselves become animate to survive—that is, they must develop emergent forms of agency and responsiveness beyond that of their human designers and operators, which allow them to prevent or mitigate forms of external interference that would disassemble them or appropriate them for other purposes. The agency of assemblages is thus as much a matter of preventing surprises as it is of generating them. Nestled among the hills west of Pasadena, the Eagle Rock substation looks extraordinary solid, even inert—a massive block of modern architecture surrounded by a well-ordered tangle of lines, switches, and electrical equipment (Figure 6). This placid exterior belies a highly dynamic system designed to compensate for the inevitable interruption or failure of its components, which include the distant generating plants in the Sierra Nevada as well the incoming high-voltage transmission lines from Big Creek and Kern River, which are silhouetted against the hills. When insulation fails—as it eventually must, given the impossibility of completely isolating any system against all possible disruptions—the effects of a complex, unpredictable, and powerful environment can be mitigated by interconnection. The success of insulation and interconnection depends not merely on human design, but also on the comingling of various nonhuman and emergent agencies. One of the results of such comingling is the invisibility to consumers of the fact that the infrastructures upon which they depend are embedded in complex, powerful, lively, and sometimes chaotic environments.

Conclusion: Strategies of Stabilization

I am sitting in a living room in Los Angeles after a long, tiring drive back from Big Creek and the Central Valley, sharing photographs of mountains, birds, generating stations, and power lines with a technically astute friend and trying with his help to understand the basic principles of three-phase electric power transmission. As we talk about nature and power, it strikes me that narratives of technological independence from nature continue to thrive in the industrialized world not only because they flatter human hubris but also because of the extraordinary fact that, in such privileged parts, the lights continue to go on despite three-year droughts and avian excrement. As envirotechnical historians have demonstrated, the infrastructures upon which we depend are inextricably entangled with their environments and with nonhuman nature, but this is only half of the story. Such systems have also been carefully, if only partially, rendered independent of their environments in ways that remain largely unexamined. As the case described above suggests, insulation and interconnection are two mechanisms that have helped make the environments in which infrastructures are embedded, if not quite irrelevant, then certainly invisible to the consumer under most circumstances.

Though the terms I have been using are drawn from the electrical power industry, the phenomena they represent can also be found elsewhere. In virtually all large technical systems some combination of practices exists that reduces the probability of environmental disruption with practices that enhance resilience in the face of those disruptions that cannot be prevented. The terms insulation and interconnection, even when not literally applicable, capture much of what is at stake in these strategies of stabilization. In some domains, such as interior heating and air conditioning, insulation may play a larger role; in others, such as transportation, interconnection may be more important. In very few systems, however, is either of these kinds of practices completely absent. As a result, the divide between technological systems and their natural environments is not simply a conceptual one—a matter of representation, or of

misrepresentation—but also one that has been built into durable practices and material infrastructures, which in turn help reinforce conceptual borders.

The problems with borders are legion, as are their critics; much scholarship in the environmental humanities is devoted to breaking them down or revealing their speciousness. When the borders in question are ontological or metaphysical ones—the line between animal and human, for example—such critique seems justified. But there are times and places when borders help maintain certain kinds of differentiation and autonomy that seem well worth preserving. As long as establishing such borders is seen as a humble, provisional project rather than a grand metaphysics—that is, one applicable in certain times and places and under certain conditions, but always subject to revision—I think there is much to be said for building certain kinds of material separations between nonhumans and humans and between infrastructures and their environments. Good fences, as they say, make good neighbors, even if good gates are essential too. The problems start when fences and gates become linked to essentialist claims about difference or sameness. By themselves, they are simply tools for living together; like other tools, they are sometimes useful and sometimes not.

Later, after I have left California and am sorting through photographs of red-tailed hawks and American crows perching blithely on transmission towers, I think back to Michener and his fellow engineers in the summer and fall of 1923, as they worked desperately to lower the rate of flashovers before the 220,000-volt upgrade was judged a failure. Innumerable birds—perhaps millions per year in North America alone, though no one knows the precise number—continue to die from accidental electrocutions and collisions with transmission lines and other human structures. Still, some have been saved by technical interventions that made potentially deadly perches inaccessible, unattractive, or better insulated.⁶² Moreover, since the 1960s, efforts have been made to protect birds even when their deaths do not threaten the stability of electric power systems. These efforts have sometimes involved physical changes to the infrastructure, such as the installation of new insulators, but they have also taken less tangible form, such as the aversion therapy provided to endangered California condors when they were reintroduced to the wild in the 1990s.⁶³ As human infrastructures engulf larger and

⁶² Precise data on the number of birds killed annually is hard to come by, particularly since power company records usually include only cases that result in service interruptions; see Scott R. Loss, Tom Will, and Peter P. Marra, “Direct Human-Caused Mortality of Birds: Improving Quantification of Magnitude and Assessment of Population Impact,” *Frontiers in Ecology and the Environment* 10 (2012): 357–364.

⁶³ On aversion therapy for condors, see A. Mee and N. F. R. Snyder, “California Condors in the 21st Century—Conservation Problems and Solutions,” in *California Condors in the 21st Century*, ed. A. Mee and L. S. Hall (Cambridge, Mass.: Nuttall Ornithological Club; Washington, DC: American Ornithological Union, 2007), 243–279; Peter S. Alagona, *After the Grizzly: Endangered Species and the Politics of Place in California* (Berkeley: University of California Press, 2013), 141. Electrical engineers and the electric power industry have developed standards for minimizing bird deaths while protecting electrical systems; see, for example, Avian Power Line Interaction Committee, *Suggested Practices for Avian Protection on Power Lines: State of the Art in 2006* (Washington, DC, and Sacramento, California: Edison Electric Institute, APLIC, and the California Energy Commission, 2006); Transmission and Distribution Committee of the IEEE Power & Energy Society, *IEEE Guide for Reducing Bird-Related Outages* (New York: Institute of Electrical and Electronics Engineers, 2011).

larger swaths of the planet, such humble strategies of differentiation and resilience, divorced from any dreams of permanent division, seem likely to become even more essential to some kind of responsible co-existence.

Attending to the practices that were used to stabilize an electric power system in the midst of an environment full of birds, bird shit, and other unpredictable and emergent agents also suggests future directions for the study of infrastructural assemblages. Because infrastructures are embedded in webs of relation that are in constant flux, the infrastructure with the most agency or vitality may well be the one that changes the least and offers the fewest surprises. The apparent inertia of infrastructures belies the constant work of adaptation and maintenance that makes it possible for even the hardest and heaviest of them to persist.⁶⁴ It is in this sense that infrastructures can be said to be animate: their solidity and durability are the products of flexibility and adaptability. In light of this paradoxically animate inanimacy, studies of durability and stabilization are a necessary complement to the studies of surprise and indeterminacy that have thus far dominated scholarship on the constitutive entanglements of humans with animals, plants, technologies, and other nonhuman actors. Industrial modernity is not just a trick of smoke and mirrors to be unveiled by identifying its inconsistencies and hypocrisies; it is also a project of concrete, steel, and wire upon which we depend for our lives. The solidity of these infrastructures and their capacity to fade from view are both products of the ongoing work of stabilization, which brings new kinds of agencies into being even as it prevents others from having unwanted effects.

Etienne Benson's research focuses on technoscientific mediations of human relations to animals and other forms of nonhuman life. He is the author of *Wired Wilderness: Technologies of Tracking and the Making of Modern Wildlife* (Johns Hopkins University Press, 2010).

ACKNOWLEDGEMENTS I am grateful to Susanne Bauer, Nils Güttler, Lisa Messeri, Christian Reiss, Martina Schlünder, and the members of the Multispecies Reading Group at the Rachel Carson Center for Environment and Society in Munich for helpful comments on earlier drafts of this article.

⁶⁴ On the overlooked importance of maintenance in the history of technology, see David Edgerton, *The Shock of the Old: Technology and Global History since 1900* (New York: Oxford University Press, 2007).

Bibliography

- Alagona, Peter S. *After the Grizzly: Endangered Species and the Politics of Place in California*. Berkeley: University of California Press, 2013.
- Alaimo, Stacy. *Bodily Natures: Science, Environment, and the Material Self*. Bloomington: Indiana University Press, 2010.
- Austin, A.O. "The High Efficiency Suspension Insulator." *Proceedings of the American Institute of Electrical Engineers* 30, no. 6 (1911): 1319-1344.
- Avian Power Line Interaction Committee, *Suggested Practices for Avian Protection on Power Lines: State of the Art in 2006*. Washington, DC, and Sacramento, Calif.: Edison Electric Institute, APLIC, and the California Energy Commission, 2006.
- Barrow, Mark V., Jr. *A Passion for Birds: American Ornithology after Audubon*. Princeton, NJ: Princeton University Press, 1998.
- Bennett, Jane. "The Agency of Assemblages and the North American Blackout." *Public Culture* 17, no. 3 (2005): 445-465.
- _____. *Vibrant Matter: A Political Ecology of Things*. Durham, NC: Duke University Press, 2010.
- "The Big Creek System," Southern California Electric Company. Accessed 2 May 2015, https://www.sce.com/NR/rdonlyres/3A43A44E-E788-4CAD-85EF-0AA8931C825A/0/FS_TheBigCreekSystem.pdf. n.d.
- "Birds and Trouble Are Synonymous." [Southern California] *Edison News* 2, no. 5, May (1943): 3.
- Bowker, Geoffrey C. *Science on the Run: Information Management and Industrial Geophysics at Schlumberger, 1920-1940*. Cambridge, Mass.: MIT Press, 1994.
- California Department of Water Resources, "Precipitation Enhancement," in *California Water Plan Update 2009*, Vol. 2—Resource Management Strategies, California Department of Water Resources Bulletin 160-09 (2009), http://www.waterplan.water.ca.gov/docs/cwpu2009/0310final/v2c10_precipenhance_cwp2009.pdf.
- Carlson, C. B. and Harold Michener. "The Vincent 220-Kv. Transmission Line: Engineering and Construction Features." *Journal of the American Institute of Electrical Engineers* 45, no. 12 (1926): 1215-1229.
- Carse, Ashley. "Nature as Infrastructure: Making and Managing the Panama Canal Watershed." *Social Studies of Science* 42, no. 2 (2012): 539-563.
- Cioc, Mark. *The Rhine: An Eco-Biography, 1815-2000*. Seattle: University of Washington Press, 2002.
- Edgerton, David. *The Shock of the Old: Technology and Global History since 1900*. New York: Oxford University Press, 2007.
- "Harold Michener, 1882-1949." *Condor* 52 March (1950): 95.
- Holmes, Frederic L. "Claude Bernard, The 'Milieu Intérieur,' and Regulatory Physiology," *History and Philosophy of the Life Sciences* 8, no. 1 (1986): 3-25.
- Horowitz, Roger. "Making the Chicken of Tomorrow: Reworking Poultry as Commodities and as Creatures, 1945-1990," in *Industrializing Organisms: Introducing Evolutionary History*, edited by Philip Scranton and Susan Schepfer, 215-235. New York: Routledge, 2004.
- Hughes, Thomas P. "The Evolution of Large Technological Systems," in *The Social Construction of Technological Systems: New Directions in the Sociology and History of Technology*, edited by Thomas P. Hughes, Wiebe E. Bijker, and Trevor J. Pinch. Cambridge, MA: MIT Press.
- _____. *Networks of Power: Electrification in Western Society*. Baltimore: Johns Hopkins University Press, 1983.
- _____. "The Seamless Web: Technology, Science, Etcetera, Etcetera." *Social Studies of Science* 16, no. 2 (1986): 281-292.

- Igler, David. *Industrial Cowboys: Miller & Lux and the Transformation of the Far West, 1850-1920*. Berkeley: University of California Press, 2001.
- Isenberg, Andrew C. *Mining California: An Ecological History*. New York: Hill and Wang, 2005.
- Jones, Christopher F. "Building More Just Energy Infrastructure: Lessons from the Past." *Science as Culture* 22, no. 2 (2013): 157-163.
- "Laguna Bell Substation." *Electrical World* 81, no. 13, 31 March (1923): 766.
- "Largest Western Hydro Plant Starts Up." *Electrical World* 82, no. 16, 20 October (1923): 830.
- Law, John. "Technology and Heterogeneous Engineering: the Case of the Portuguese Expansion," in *The Social Construction of Technological Systems: New Directions in the Sociology and History of Technology*, edited by Wiebe E. Bijker, Thomas Parke Hughes, and Trevor J. Pinch, 111-133. Cambridge, Mass.: MIT Press, 1987.
- Longcore, Travis and Catherine Rich. "Ecological Light Pollution." *Frontiers in Ecology and the Environment* 2, no. 4 (2004): 191-198.
- Loss, Scott R., Tom Will, and Peter P. Marra. "Direct Human-Caused Mortality of Birds: Improving Quantification of Magnitude and Assessment of Population Impact." *Frontiers in Ecology and the Environment* 10 (2012): 357-364.
- Macferran, Mabel and Harald Michener. "High-Voltage Transmission of Power." *The LOG*, January (1930): 25-28.
- McIntosh, H.A. "Changing Lines to 220,000 While Hot." *Electrical World* 82, no. 14, 6 October (1923): 695-697.
- Mee, A. and N. F. R. Snyder, "California Condors in the 21st Century—Conservation Problems and Solutions," in *California Condors in the 21st Century*, edited by A. Mee and L. S. Hall, 243-279. Cambridge, MA: Nuttall Ornithological Club; Washington, DC: American Ornithological Union, 2007.
- Michener, Harold. "Description of the System and Operating Experiences." *Journal of the American Institute of Electrical Engineers* 43, no. 10 (1924): 1222-1225.
- _____. "The Edison Line From Boulder Dam." *Electrical Engineering* 58, no. 11 (1939): 463-465.
- _____. "Where Engineer and Ornithologist Meet: Transmission Line Troubles Caused by Birds." *Condor* 30, no. 3 (1928): 169-175.
- Mooallem, Jon. "Squirrel Power!" *New York Times*, 31 August, 2013. Accessed 15 May 2015, <http://www.nytimes.com/2013/09/01/opinion/sunday/squirrel-power.html>.
- Myers, William A. *Iron Men and Copper Wires: A Centennial History of the Southern California Edison Company*, 2nd ed., rev. Glendale, Calif.: Trans-Anglo Books, 1986.
- Nash, Linda. *Inescapable Ecologies: A History of Environment, Disease, and Knowledge*. Berkeley: University of California Press, 2006.
- Netz, Reviel. *Barbed Wire: An Ecology of Modernity*. Middeltown, Conn.: Wesleyan University Press, 2004.
- "Obituary: Josephine R. Michener." *Condor* 73, no. 2 (1971): 256.
- "Operation of Transmission Systems." *Electrical World* 57, no. 22, 1 June (1911): 1423-1425.
- Paxson, Heather and Stefan Helmreich. "The Perils and Promises of Microbial Abundance: Novel Natures and Model Ecosystems, from Artisanal Cheese to Alien Seas." *Social Studies of Science* 44, no. 2 (2014): 165-193.
- Peek, F. W., Jr. "The Law of Corona and the Dielectric Strength of Air." *Transactions of the American Institute of Electrical Engineers* 30, no. 3 (1911): 1889-1965.
- Peirson, Charlie. "Playing Chess with Nature," in *Edison Partners, Special Edition Relating to the Building of the New Electric Giant of the Pacific Coast*, 7 September, 1923.
- Perrow, Charles. *Normal Accidents: Living with High-Risk Technologies*. New York: Basic Books, 1984.
- Plumwood, Val. "Shadow Places and the Politics of Dwelling." *Australian Humanities Review* 44 (2008).

- Prichard, Sara B. and Thomas Zeller. "The Nature of Industrialization," in *The Illusory Boundary: Environment and Technology in History*, edited by Martin Reuss and Stephen H. Cutcliffe. Charlottesville: University of Virginia Press, 2010.
- Pritchard, Sara B. *Confluence: The Nature of Technology and the Remaking of the Rhône*, Cambridge, Mass.: Harvard University Press, 2011.
- Quinton, Amy. "Drought Could Cost California Agriculture Industry \$1.7 Billion." KVPR Radio, 19 May, 2014. Accessed 2 May 2015, <http://kvpr.org/post/drought-could-cost-california-agriculture-industry-17-billion>.
- Redinger, David H. *The Story of Big Creek*, with new material by Edith I. Redinger and William A. Myers. Glendale, Calif.: Trans-Anglo Books, 1987.
- Sheehan, Tim. "High Sierra Regatta Canceled by Low Water at Huntington Lake." *Fresno Bee*, 2 April, 2014. Accessed 2 May 2015, <http://www.fresnobee.com/2014/04/02/3856414/high-sierra-regatta-canceled-by.html>.
- Sorenson, R. W., H. H. Cox, and G. E. Armstrong. "California 220,000-volt-1100-Mile-1,500,000-kw. Transmission Bus." *Proceedings of the American Institute of Electrical Engineers* 38, no. 9 (1919): 1027-1038.
- "Southern California Edison Plans New Capitalization." *Electrical World* 82, no. 5, 4 August (1923): 245.
- Star, Susan Leigh and Karen Ruhleder. "Steps toward an Ecology of Infrastructure: Design and Access for Large Information Spaces." *Information Systems Research* 7, no. 1 (1996): 111-134.
- Stauffacher, E. R. "Automatic Protection—Balanced Relays and Flashover Control." *Journal of the American Institute of Electrical Engineers* 43, no. 10 (1924): 1225-1228.
- Stoll, Steven. *The Fruits of Natural Advantage: Making the Industrial Countryside in California*. Berkeley: University of California Press, 1998.
- Sub-Committee on Overhead Line Construction of the National Electric Light Association. *Handbook on Overhead Line Construction*, 3rd ed. New York: National Electric Light Association, 1917.
- Tice, H. W., A. A. Kroneberg, W. N. Johnson, J. D. Enefer, E. E. Tugby, and C. L. Sidway. "A System Frequency Change." *Electrical Engineering* 67, no. 9 (1948): 866-881.
- Transmission and Distribution Committee of the IEEE Power & Energy Society. *IEEE Guide for Reducing Bird-Related Outages*. New York: Institute of Electrical and Electronics Engineers, 2011.
- "Transmission at 220 Kv. on the Southern California Edison System: A Symposium." *Transactions of the American Institute of Electrical Engineers* 43 (1924): 1222-1237.
- Vicuña, Sebastian, John A. Dracup, and Larry Dale. "Climate Change Impacts on the Operation of Two High-Elevation Hydropower Systems in California." California Climate Change Center, August 2009. Accessed 2 May 2015, <http://www.energy.ca.gov/2009publications/CEC-500-2009-019/CEC-500-2009-019-F.PDF>.
- White, Richard. *The Organic Machine*. New York: Hill and Wang, 1995.
- Wilson, Robert M. *Seeking Refuge: Birds and Landscapes of the Pacific Flyway*. Seattle: University of Washington Press, 2010.
- Wood, R.J.C. "220-Kv. Transmission Transients and Flashovers." *Journal of the American Institute of Electrical Engineers* 44, no. 11 (1925): 1211-1218.
- _____. "220-Kv. Transmission Transients and Flashovers." *Journal of the American Institute of Electrical Engineers* 44, no. 11, November (1925): 1211-1219.
- _____. "Spray and Fog Tests on 220-Kv. Insulators." *Journal of the American Institute of Electrical Engineers* 48, no. 12 (1929): 900-904
- Woodbury, Edward. "150,000-Volt Transmission System: Some Operating Characteristics of the Big Creek Development of the Pacific Light & Power Corporation." *Proceedings of the American Institute of Electrical Engineers* 33, no. 9 (1914): 1359-1370.
- Worster, Donald. *Rivers of Empire: Water, Aridity, and the Growth of the American West*. New York: Oxford University Press, 1985.